

Product Specifications

Pump Type:	Fixed Displacement Piston Type
Rotation:	CW or CCW
Speed:	600 RPM to 3000 RPM*
Unloading Valve:	Integral and Pressure Adjustable
Normal Pressure Cut Out:	3000 psi (207 bar)
Normal Pressure Cut In:	2500 psi (172 bar)
Weight:	7.0 lbs. (3.2 kg)
MAWP:	3000 psi (207 bar)
Recommended Fluid:	Red hydraulic fluid (MIL-H-5606)
Inlet Connection:	SAE #6
Outlet Connection:	SAE #4
Return Connection:	SAE #4
Output Shaft:	9 Tooth Spline
Flange:	2 Bolt, SAE A
Service Kit:	KT-202788

*Operation at speeds in excess of 3000 RPM may result in pump damage. Please consult factory on high speed applications.

RPA-308191

Revised August 2014

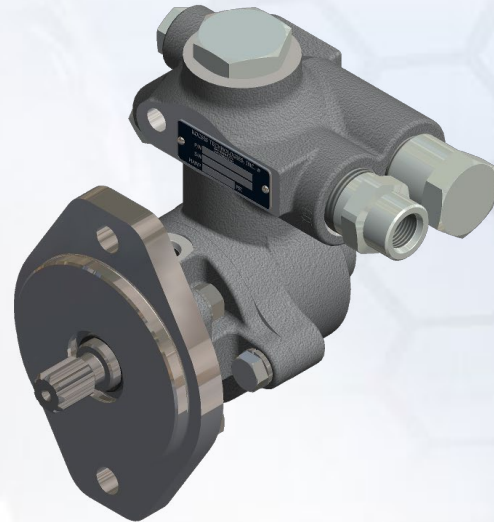

Pump Performance

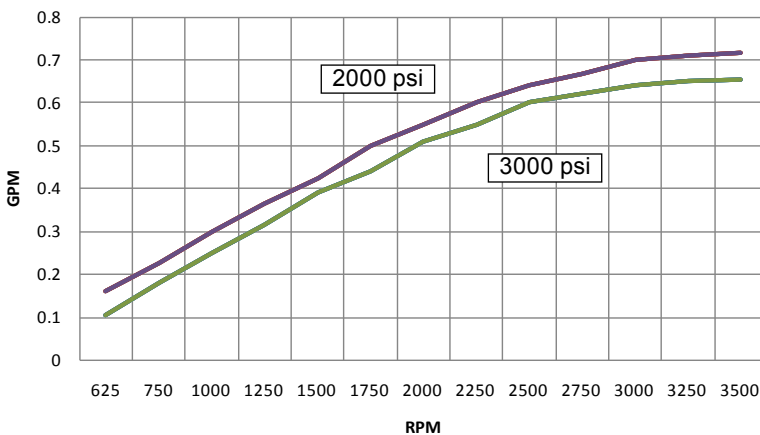

Mounting Specifications

Model	Mounting Flange			Drive Shaft	
	ANSI	USA	SAE	ANSI	(SAE)*
RPA-308191	82-2	2F32	A	16-4	(A)

*Reference letters indicate the matching SAE mounting flange

General Dimensions

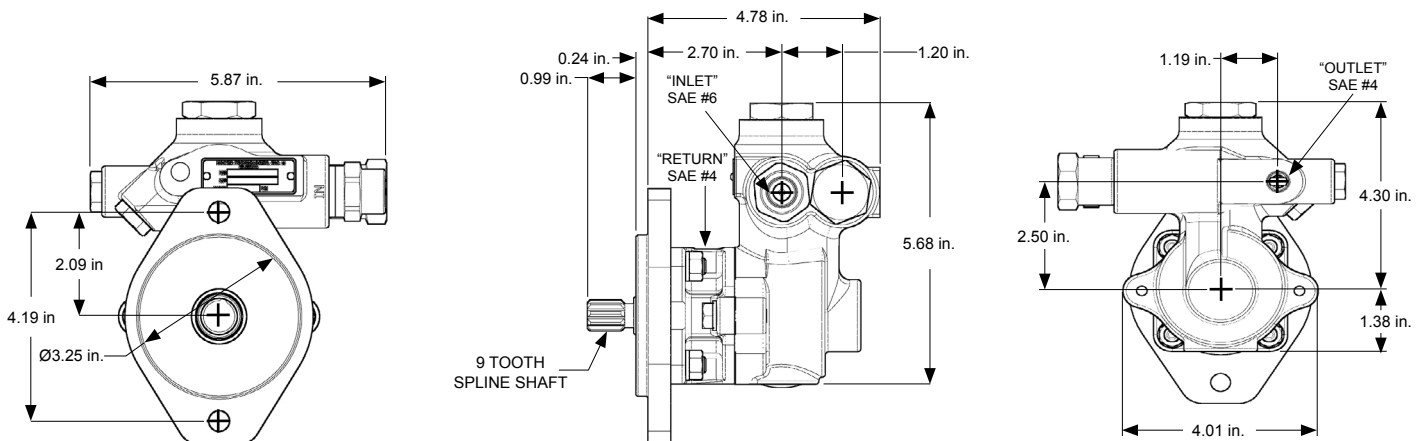

SSRPA191_C